

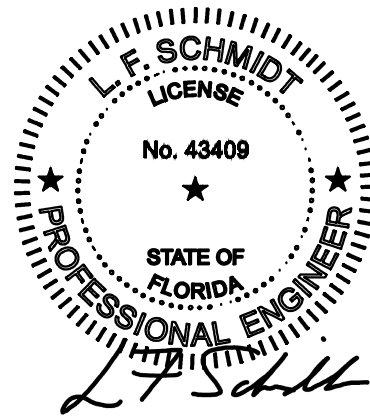

3501 CR 6 EAST  
ELKHART, IN 46514



This item has been digitally signed and sealed by L. F. Schmidt, P.E. on the date adjacent to the seal.

Printed copies of this document are not considered signed and sealed and the signature must be verified on any electronic copies.

THIS PRODUCT APPROVAL IS VALID ONLY FOR THE STATE OF FLORIDA

# MODEL 9750 PVC SINGLE HUNG WINDOW w/ NAILING FIN "NON-IMPACT"

### GENERAL NOTES

1. This product anchoring drawing has been developed in compliance with the 8th Edition (2023) Florida Building Code (FBC) excluding the "High Velocity Hurricane Zone". See the Certification Agency Certificate for sizes, specifications and ratings.
2. Product anchors shall be as listed and spaced as shown on details. Anchor embedment to base material shall be beyond wall dressing, stucco, foam, brick and other wall coverings.
3. Wood screws shall be installed following installation instructions of ANSI/AWC NDS 2018. All other fastener types to be installed following fastener manufacturer's installation instructions.
4. Fastener embedment depths, edge distances and center-center distances shall be as specified by the fastener manufacturer but in no instance shall they be less than shown in this drawing.
5. Where shims are used, they must be a "rigid / stiff" material that complies with the requirements of the FBC.
6. Positive and negative design pressure requirements for use with this drawing shall be determined by others for specific jobs in accordance with the governing code.
7. Site conditions not covered by this drawing are subject to further engineering analysis.

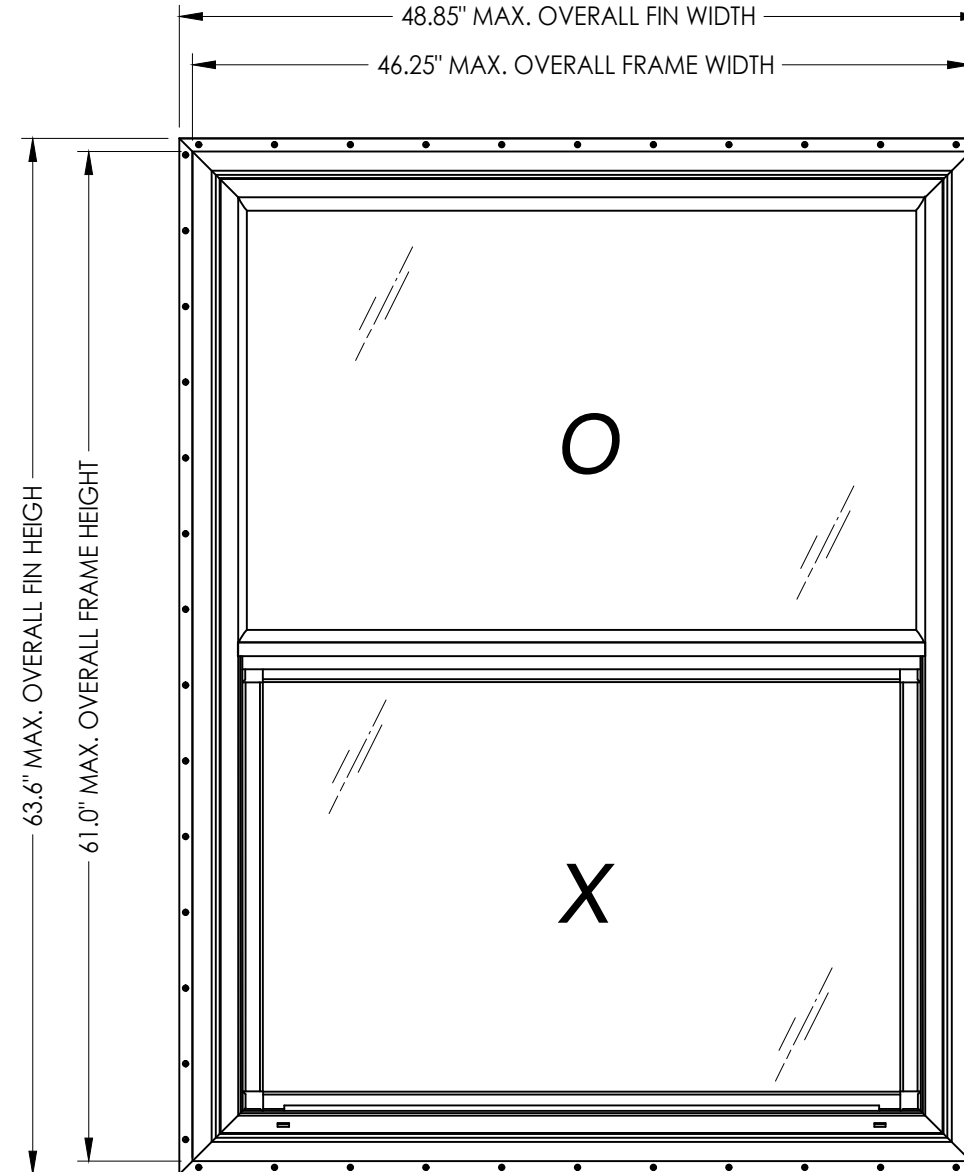

TABLE OF CONTENTS	
SHEET #	DESCRIPTION
1	Typical elevation, design pressures & general notes
2	Horizontal & vertical cross sections & bill of materials
3	Horizontal & vertical cross sections and glazing detail
4	Buck & frame anchoring

MAX. O.A. FIN DIMENSION	MAX. O.A. FRAME DIMENSION	DESIGN PRESSURE (PSF)	
		POSITIVE	NEGATIVE
48.85" x 63.6"	46.25" x 61.0"	+50.0	-50.0

Documents Prepared By:  
Lyndon F. Schmidt  
P.E. No. 43409

*RW* BUILDING CONSULTANTS, INC.  
P.O. Box 230, Valrico, FL 33595  
Phone No.: 813.659.9197  
FBPE Registry No. 9813

PRODUCT: SINGLE HUNG WINDOW  
PART OR ASSEMBLY: TYPICAL ELEVATION, DESIGN PRESSURES & GENERAL NOTES

NO.	DATE	REVISIONS			
		UPDATE TO	ED.	BY	DATE
9	9/18/23	UPDATE TO	8TH ED.	(2023)	FBC
8	9/03/20	UPDATE TO	7th ED.	(2020)	FBC
7	10/03/17	UPDATE TO	6th ED.	(2017)	FBC
6	2/23/16	REVISE	FRAME SIZE	(NEW TEST)	LFS
5	2/23/15	UPDATE TO	5TH ED.	(2014)	FBC

DATE: 6/01/10  
SCALE: N.T.S.  
DWG. BY: AP  
CHK. BY: LFS  
DRAWING NO.: FL-993.1  
SHEET 1 OF 4

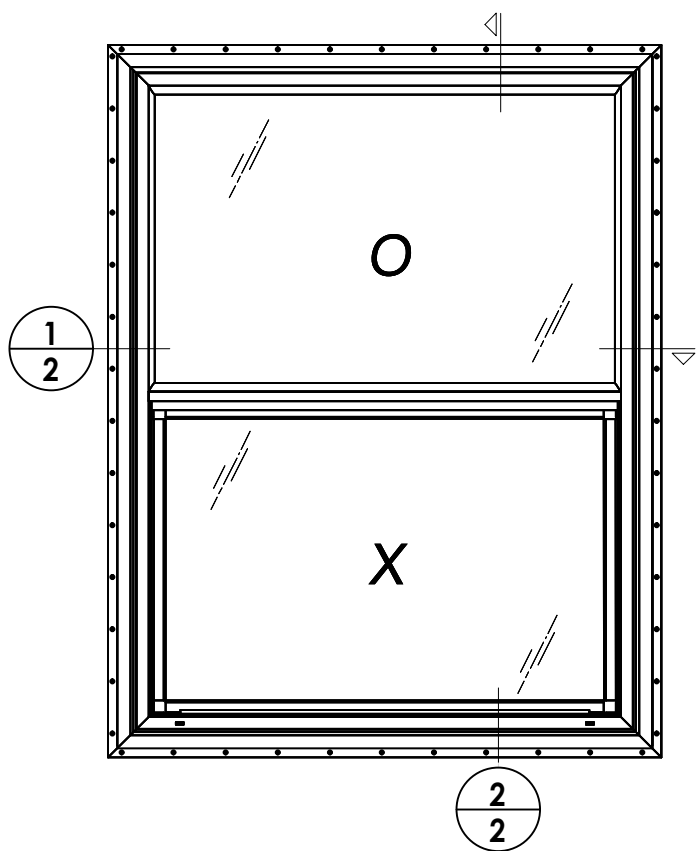

BILL OF MATERIALS		
ITEM	DESCRIPTION	MATERIAL
A	1/4" MAX. SHIM SPACE	-
B	2X BUCK (SG >= 0.42)	WOOD
C	MASONRY - 3,000 PSI MIN. CONCRETE CONFORMING TO ACI 301 OR HOLLOW BLOCK CONFORMING TO ASTM C90	CONCRETE
D	#8 X 1-3/4" PPH SMS (1-1/2" MIN. EMBEDMENT)	STEEL
E	1/4" X 2-3/4" DeWALT OR ITW CONCRETE SCREW	STEEL
F	#8 X 2-1/4" PPH SMS (1-1/2" MIN. EMBEDMENT)	STEEL
G	2X FRAMING (SG >= 0.42)	WOOD

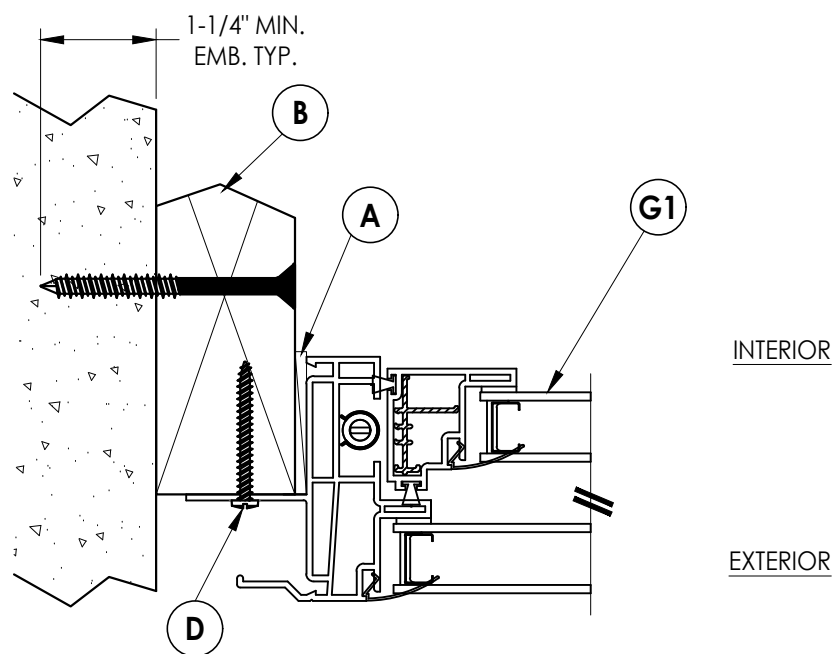

**1**  
**2** HORIZONTAL CROSS SECTION

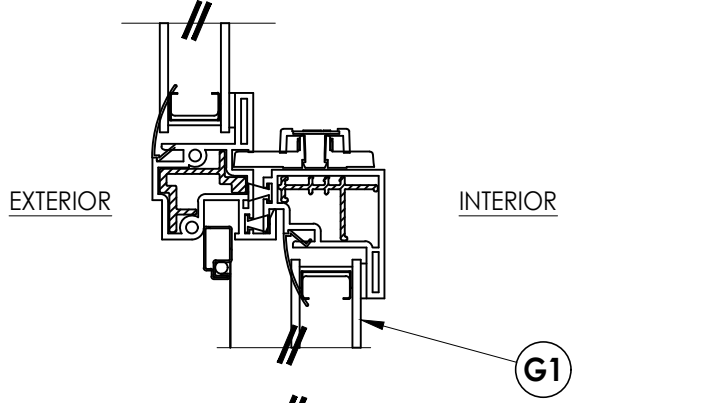
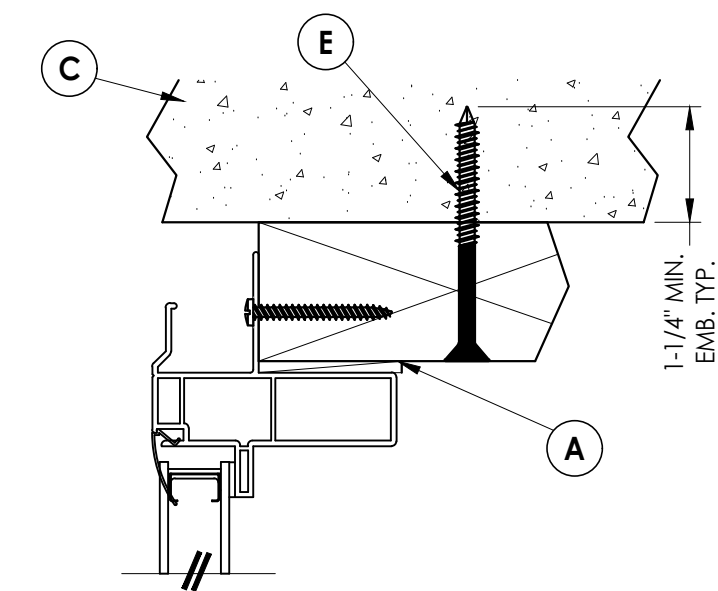
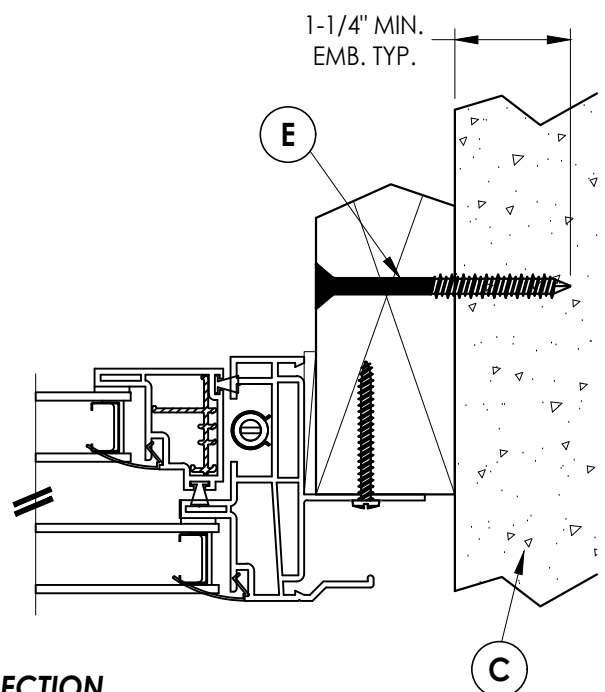

**2**  
**2** VERTICAL CROSS SECTION

Documents Prepared By:  
Lyndon F. Schmidt  
P.E. No. 43409

**RW** BUILDING CONSULTANTS, INC.  
P.O. Box 230, Vairico, FL 33595  
Phone No.: 813.659.9197  
FBPE Registry No. 9813

PRODUCT: SINGLE HUNG WINDOW

PART OR ASSEMBLY: HORIZONTAL & VERTICAL CROSS SECTIONS & BILL OF MATERIALS

NO.	DATE	REVISIONS
9	9/18/23	UPDATE TO 8TH ED. (2023) FBC
8	9/03/20	UPDATE TO 7th ED. (2020) FBC
7	10/03/17	UPDATE TO 6th ED. (2017) FBC
6	2/23/15	REVISE FRAME SIZE (NEW TEST)
5	2/23/15	UPDATE TO 5TH ED. (2014) FBC
		BY

DATE: 6/01/10

SCALE: N.T.S.

DWG. BY: AP

CHK. BY: LFS

DRAWING NO.: FL-993.1

SHEET 2 of 4

© 2010 R.W. BUILDING CONSULTANTS INC.

Z:\2023 FBC Drawings\Lippert Components, Inc\FL-993 R19\FL-993.1.dwg

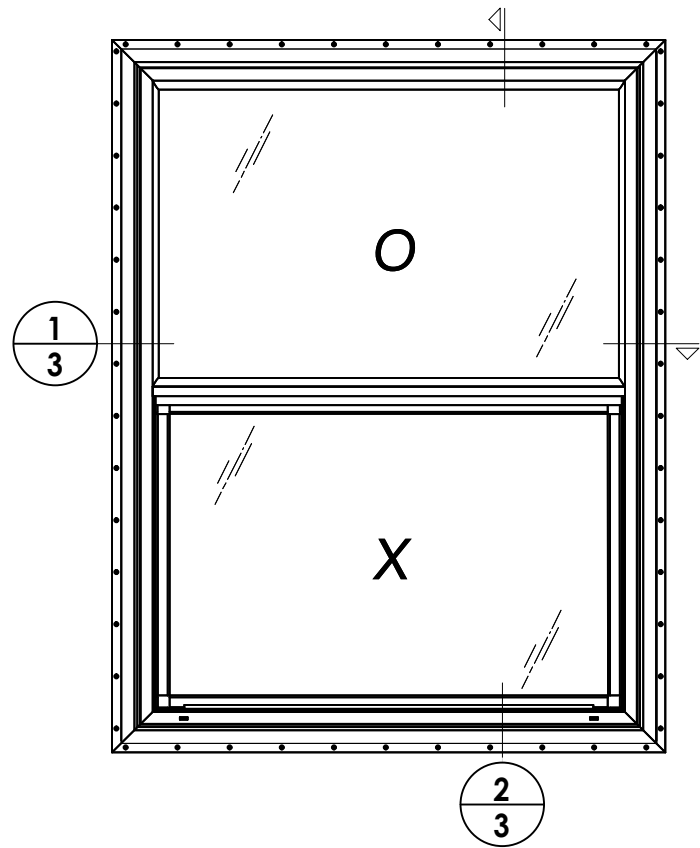

**1**  
**3** HORIZONTAL CROSS SECTION

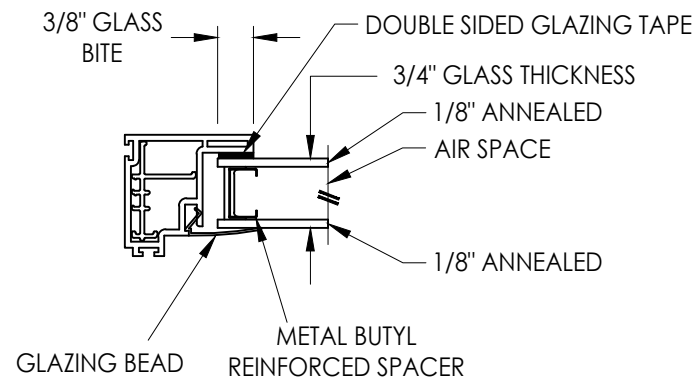

**G1** GLAZING DETAIL

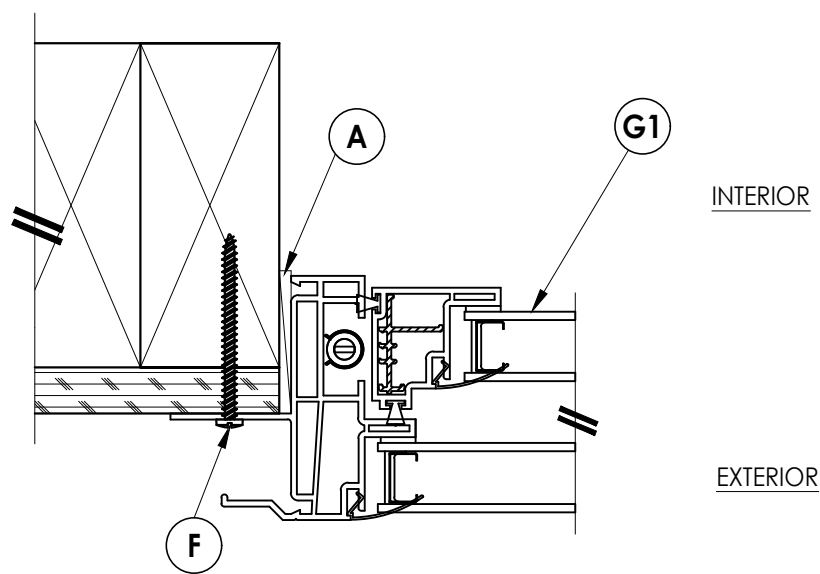

**1**  
**3** HORIZONTAL CROSS SECTION

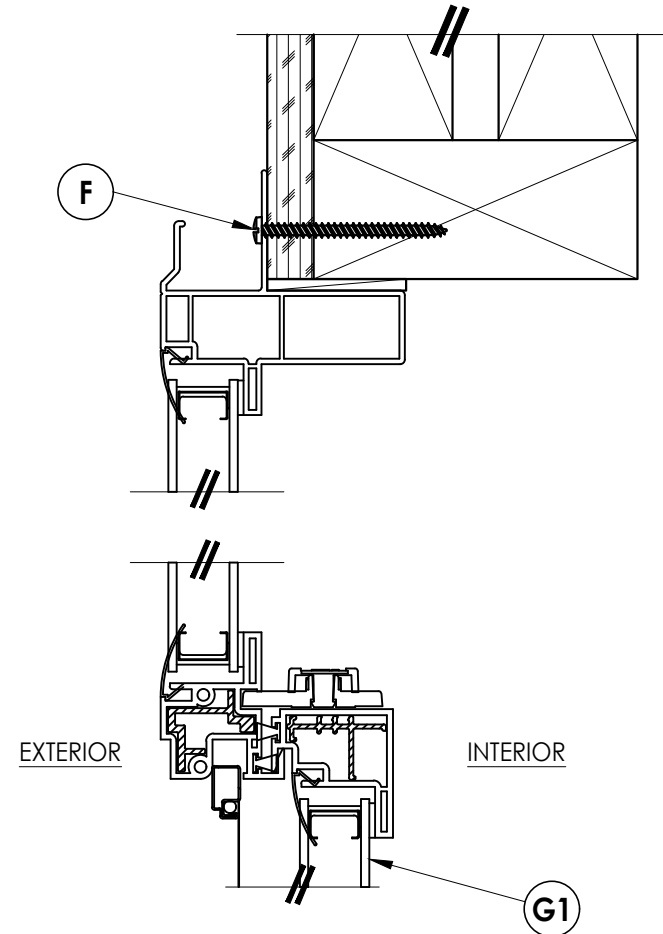
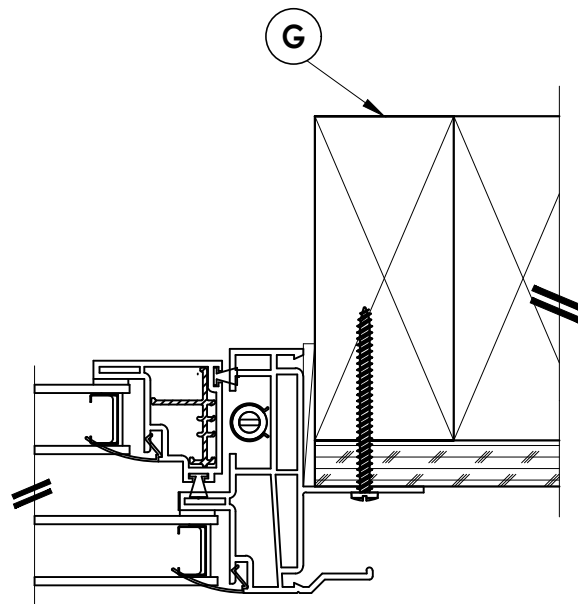

**2**  
**3** VERTICAL CROSS SECTION

Documents Prepared By: Lyndon F. Schmidt P.E. No. 43409		BUILDING CONSULTANTS, INC. P.O. Box 230, Vairico, FL 33595 Phone No.: 813.659.9197 FBPE Registry No. 9813	
PRODUCT: SINGLE HUNG WINDOW		PART OR ASSEMBLY: HORIZONTAL & VERTICAL CROSS SECTIONS AND GLAZING DETAIL	
9	9/18/23	UPDATE TO 8TH ED. (2023)	FBC
8	9/03/20	UPDATE TO 7th ED. (2020)	FBC
7	10/03/17	UPDATE TO 6th ED. (2017)	FBC
6	2/23/15	REVISE FRAME SIZE (NEW TEST)	LFS
5	2/23/15	UPDATE TO 5TH ED. (2014)	FBC
	NO.	DATE	BY
REVISIONS			
DATE: 6/01/10			
SCALE: N.T.S.			
DWG. BY: AP			
CHK. BY: LFS			
DRAWING NO.: FL-993.1			
SHEET 3 OF 4			

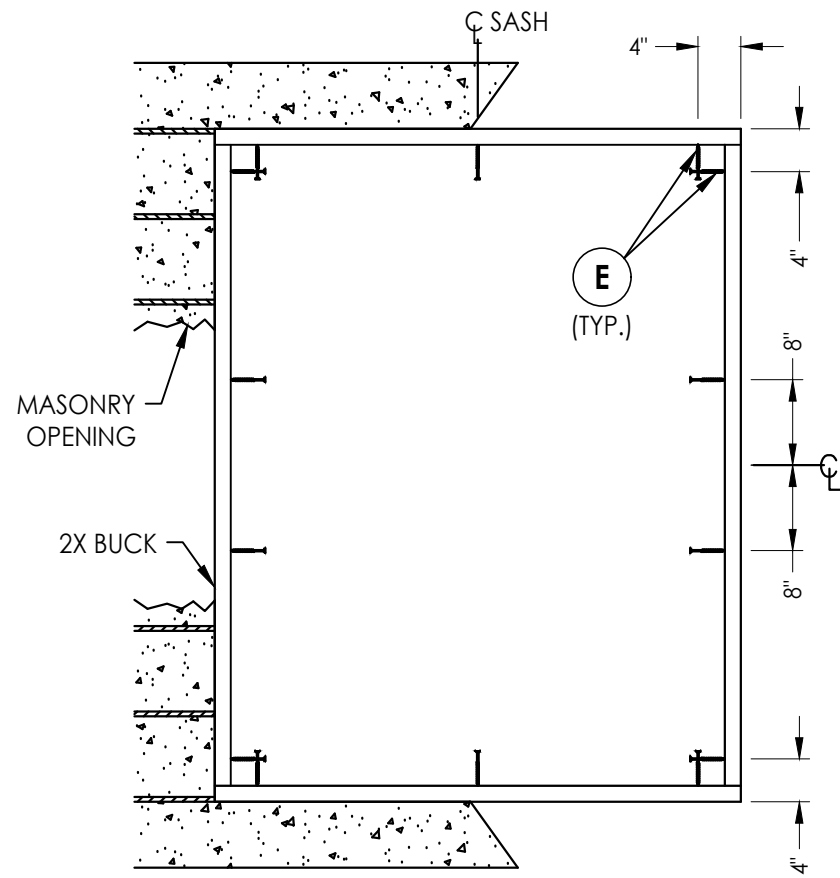

**BUCK ANCHORING**

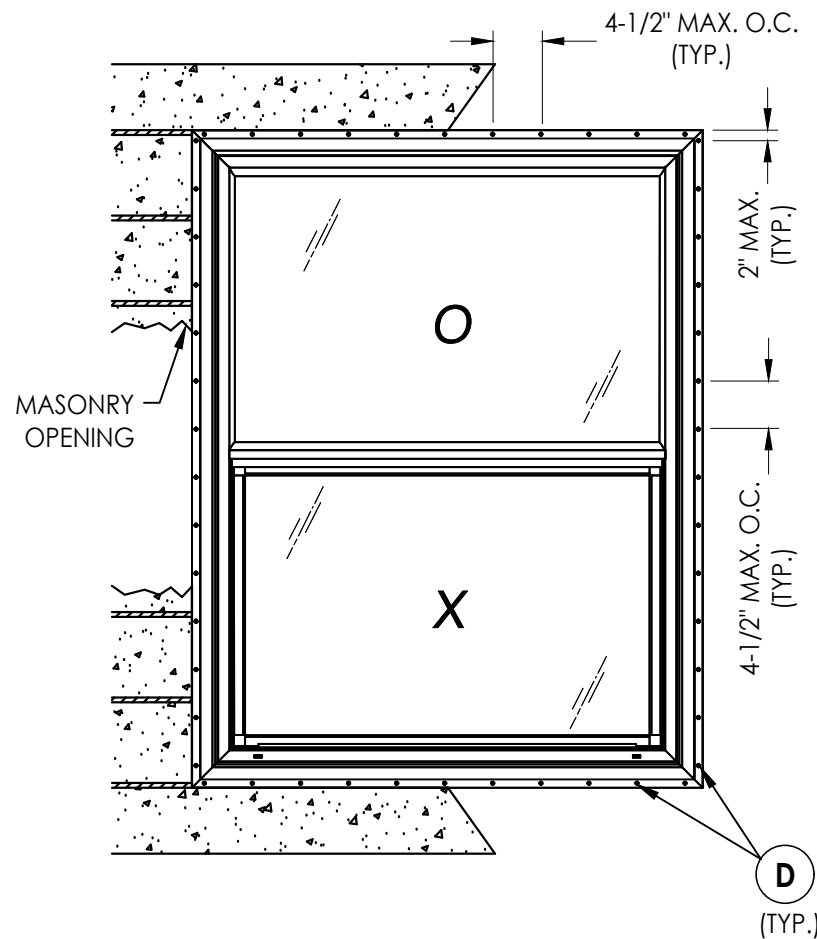

**FRAME ANCHORING**  
MASONRY CONSTRUCTION

2X FRAMING TO BE  
DESIGNED BY THE ENGINEER  
OR ARCHITECT OF RECORD

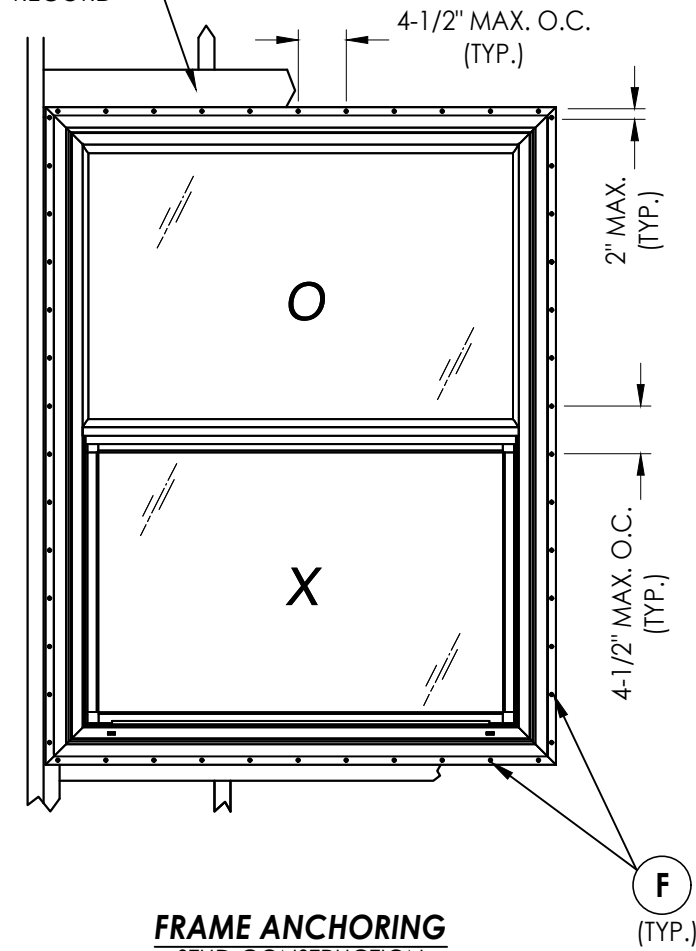

**FRAME ANCHORING**  
STUD CONSTRUCTION

**CONCRETE ANCHOR NOTES:**

- Concrete anchor locations at the corners may be adjusted to maintain the min. edge distance to mortar joints.
- Concrete anchor locations noted as "MAX. ON CENTER" must be adjusted to maintain the min. edge distance to mortar joints, additional concrete anchors may be required to ensure the "MAX. ON CENTER" dimension are not exceeded.
- Concrete anchor table:

ANCHOR TYPE	ANCHOR SIZE	MIN. EMBEDMENT	MIN. CLEARANCE TO MASONRY EDGE	MIN. CLEARANCE TO ADJACENT ANCHOR
ITW TAPCON®	1/4"	1-1/4"	2"	4"
DeWALT ULTRACON+®	1/4"	1-1/4"	1"	4"

**WOOD SCREW INSTALLATION NOTES:**

- Maintain a minimum 5/8" edge distance, 1" end distance, & 1" o.c. spacing of wood screws to prevent the splitting of wood.

Documents Prepared By:  
Lyndon F. Schmidt  
P.E. No. 43409

**RW** BUILDING CONSULTANTS, INC.  
P.O. Box 230, Valrico, FL 33595  
Phone No.: 813.659.9197  
FBPE Registry No. 9813

PRODUCT:  
SINGLE HUNG WINDOW

PART OR ASSEMBLY:  
BUCK & FRAME ANCHORING

NO.	DATE	REVISIONS
9	9/18/23	UPDATE TO 8TH ED. (2023) FBC LFS
8	9/03/20	UPDATE TO 7TH ED. (2020) FBC DAC
7	10/03/17	UPDATE TO 6TH ED. (2017) FBC JK
6	2/23/16	REVISE FRAME SIZE (NEW TEST) LFS
5	2/23/15	UPDATE TO 5TH ED. (2014) FBC JK
		BY

DATE: 6/01/10

SCALE: N.T.S.

DWG. BY: AP

CHK. BY: LFS

DRAWING NO.:

FL-993.1

SHEET 4 OF 4